

FLUFF/FIBER & S.A.P. RECLAIM SYSTEM

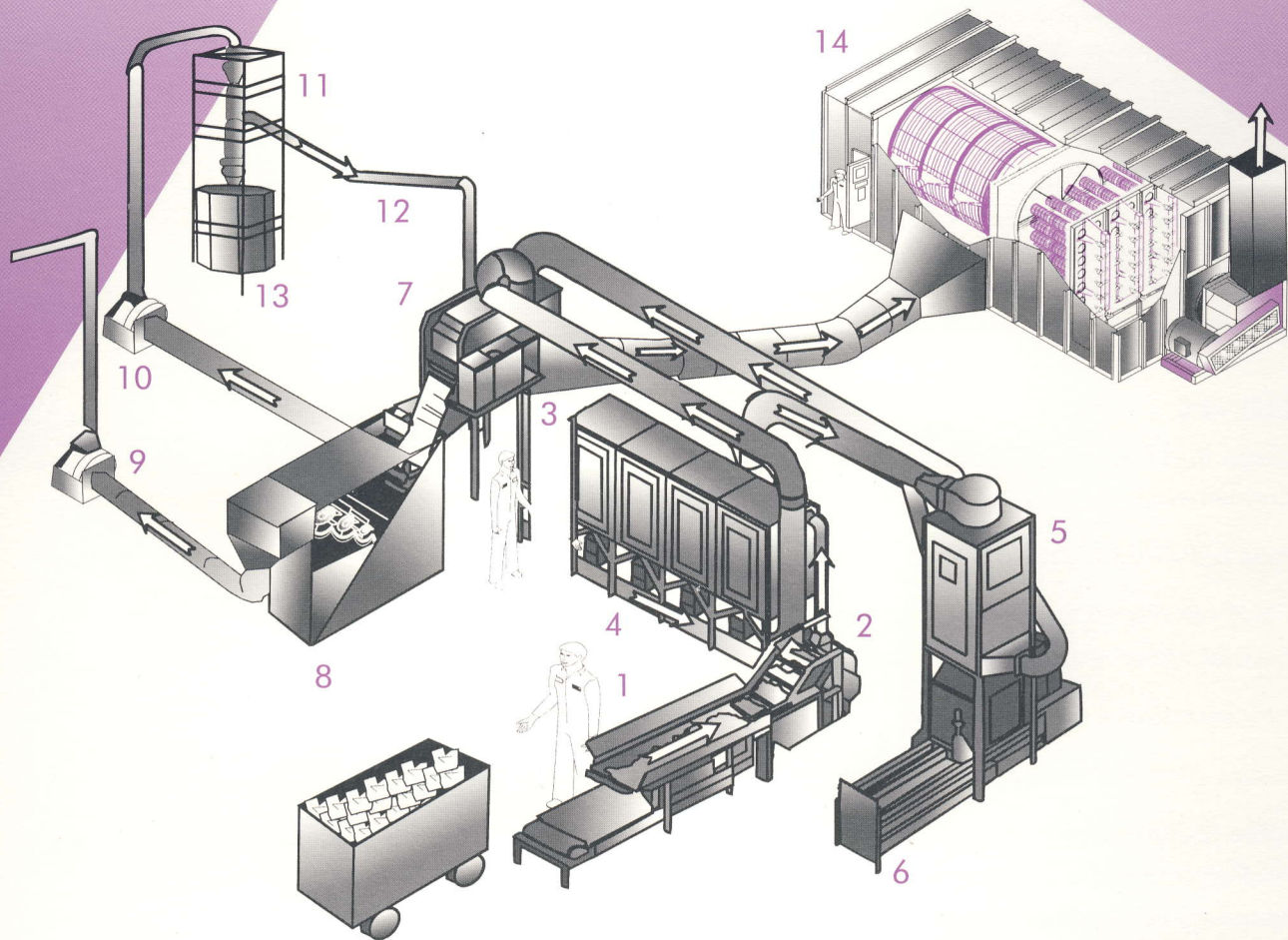

1. Reject Product Hopper
2. Buster Fan
3. Multi-Stage Separator
4. Scrap Fans (behind separator)
5. Scrap Collector
6. Scrap Baler
7. Fluff Condenser
8. S.A.P. Extractor
9. Fluff Fan to Process/Volumetric Feeder
10. S.A.P. Fan to Aspirator
11. Cyclone and Aspirator/Classifier
12. Residual Fluff to Condenser
13. Reclaimed S.A.P.
14. Rotary Drum Filter System

Design

Separate and reclaim fluff/fiber/s.a.p. from reject products containing significant quantities of fiber, s.a.p. and other absorbent materials.

Application

Disposable hygienic product manufacturing processes: baby diapers, feminine hygiene products, incontinence products, soaker pads and other absorbent pads plus related non-wovens.



Air & Fiber Handling Specialist

FLUFF/FIBER & S.A.P. RECLAIM SYSTEM

Design

Separate light, fluffy material from heavier, high density products using air classification in a multi-stage separator. SAP can then be extracted from the fiber.

Application

Originally developed for reclaim of disposable baby diapers, the IBIS system is also used for adult incontinence products, feminine hygiene pads nonwovens and other similar products.

Features

- ▲ Separate fluff from scrap material (poly and nonwoven)
- ▲ Extracts SAP/SAM from Fluff/Fiber
- ▲ Poly and nonwoven collected for baling or thermal fusion extrusion
- ▲ Factory assembled module
- ▲ Processes products containing SAP/SAM
- ▲ Versatile design allows continuous separation and metering to process or independent of separation and metering
- ▲ Conveying air provided and cleaned by IBIS Rotary Drum Filter and Final Fiber
- ▲ Volumetric feeder metering of fluff back to process

Options

- ▲ SAP/SAM Extraction System
- ▲ Final Filter – Hi-efficiency
- ▲ Bale Opener/Debaler
- ▲ Manual feed system
- ▲ Complete duct packages
- ▲ Spare Parts, field service training
- ▲ Integrated "cull" collection
- ▲ Automatic introduction of reject product with PLC interface
- ▲ Fluff conveying storage and metering to multiple production lines
- ▲ Complete Dust Level surveys and Air Quality Testing



P.O. Box 670
Hoschton, Georgia 30548, USA

1-800-682-2062
Phone: 706-654-3232
Fax: 706-654-3888
email: sales@ibis-usa.com
http://www.ibis-usa.com

Model	Approximate Input Capacity	Electrical Requirements	Space Requirements
FSS-50	150 kg/hr (330 lb/hr)	85 h.p. (65 kw)	700 ft ² /65m ²
FSS-150	300 kg/hr (660 lb/hr)	175 h.p. (130 kw)	2000 ft ² /186m ²
FSS-200	400 kg/hr (880 lb/hr)	200 h.p. (150 kw)	3000 ft ² /280m ²

*Specifications may vary with your custom system